



The World Leader in Bus Air Conditioning Compressors "TM31/DKS-32 Zexel Japan".

The **TM31/DKS32** [313cc] manufactured by Zexel & Made in Japan [Diesel Kiki] has been around for many years and approved by major "OE" Bus a/c system Manufacturers through out the world. This very same model as manufactured by Zexel [Diesel Kiki] is also known as:

- Seltec TM31
- Thermoking TM31
- ICE TM31
- Carrier TM31

Worldaire has very competitive prices for your consideration and stock available.



DKS-32 Made In Japan



Labeled by "Zexel"



Zexel swash-plate Compressor.



Zexel Excellent Operating Stability.



Zexel Low Vibration



Zexel Quiet Operation



Service Valves



Service Valves



TM31/DKS-32 Catalog Link:

Compressor Assembly	
Worldaire Part Number	Cross Reference
13-46500	488-46500
13-46510	488-46510
13-46520	488-46520
13-46530	488-46530
13-46540	488-46540
13-46550	488-46550

COMPRESSOR		
Type	Mount Style	Oil
TM31	Direct	Y
TM31	Direct	Y
TM31	Direct	Y
TM31	Direct	Y
TM31	Direct	Y
TM31	Direct	Y

MANIFOLD	
Fitting Type	Fitting Description
Bolt	1-1/16 x 7/8
Bolt	1-1/16 x 7/8
Bolt	1-1/16 x 7/8
Bolt	1-1/16 x 7/8
Bolt	1-1/16 x 7/8
Bolt	1-1/16 x 7/8

CLUTCH			
Pulley Diameter (mm)	Pulley Type	Notes	Voltage (V)
152	2A	3E	12
152	2A	3E	24
152	2B	3E	12
152	2B	3E	24
152	8PV	3E	12
152	8PV	3E	24

Contact sales : dave@worldaire.com

·ZEXEL·

COMPRESSOR

压 缩 机



DKS-32

ZEXEL COLD SYSTEMS COMPANY

株式会社 杰克赛尔制冷系统

DKS-32

System outline:

ZEXEL's swash-plate compressor is renowned for its excellent operating stability, low vibration and quiet operation.

系统概要：

杰克赛尔的斜盘式压缩机以其优质的可靠性，小振动，低噪音而闻名。

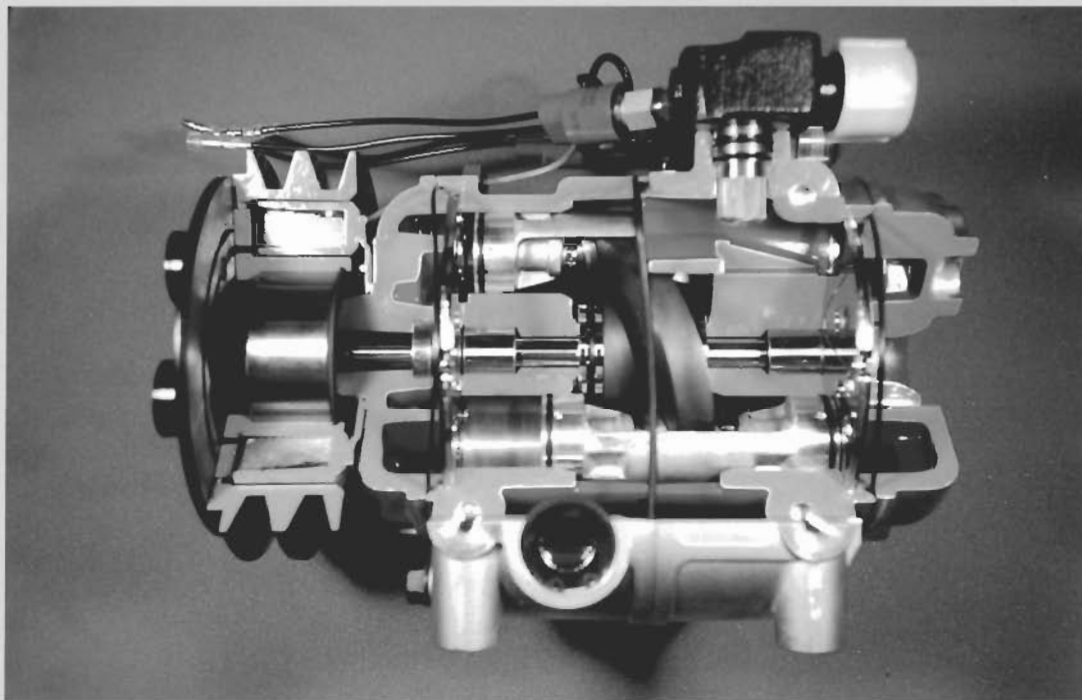

Major advantages:

1. Reliability

In addition to their superb durability, this compressor employs the force-circulation type oil pump, and the special metal all of sliding portion applications.

2. Stability

A stable cooling capacity is secured through the entire operating range, including low-speed operation.

3. Capacity

This compressor is proud of the biggest capacity the fastest speed in the world.

These benefits are complemented by the symmetrically reciprocating movement of its 10 cylinder.

主要性能：

1. 耐久性

除其耐久性以外，此压缩机带有强制循环油泵，使其即使用在重型车上也可发挥高性能。

2. 高效率

其稳定的制冷能力来自完整的工作范围，包括低速运转。

3. 此种型号的压缩机以其容量大，速度快而闻名世界。

我们为此而感到自豪。

除这些优点外其10个活塞均可往复运动。

DKS-32压缩机是客车用重型压缩机，可广泛应用于大客车，冷冻车，重型卡车，火车和其他车辆。

Specifications 规格

MODEL: 型号	DKS-32
Displacement 排量	313cm ³ /rev
Number of cylinders 气缸数	10
Maximum speed 最大速度	7000r/min
Refrigerant 制冷剂	HFC-134a
Lubricant 润滑油	ZXL 100PG(DH PS) 500cm ³
Weight(without clutch) 重量(没有电磁阀)	10.0kg
Weight(with clutch) 重量(有电磁阀)	14.5kg
Voltage 电压	DC 12/24V
Power consumption 耗电量	48W

Performance Curve 性能

TEST CONDITIONS Dis. Pressure: 1.52MPa (gage)
Suc. Pressure: 0.182MPa (gage)

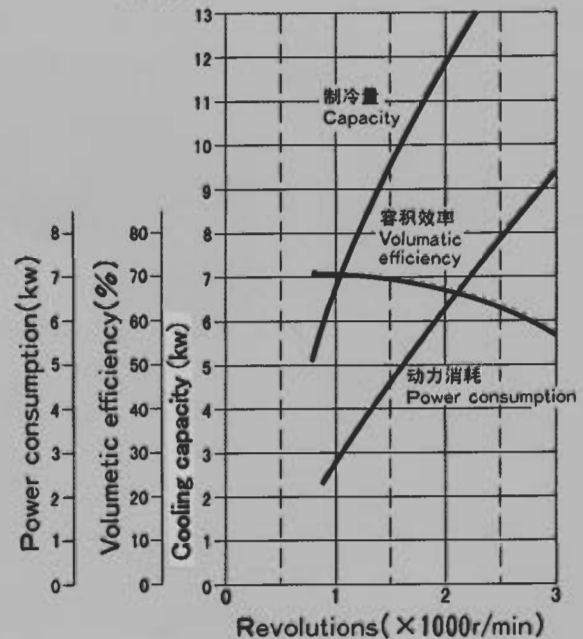

Mountings 安装

Example 1:

(Mounted directly on the engine)

(直接安装在发动机上)

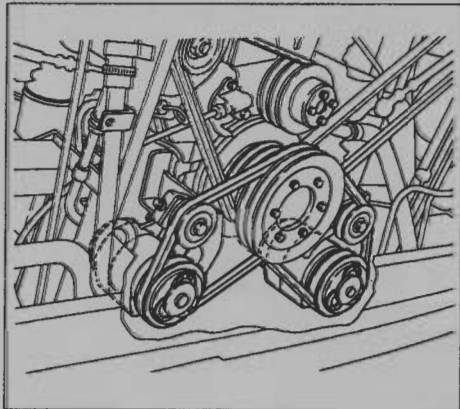

Example 2:

(Mounted on the chassis)

(安装在底盘上)

